



ロビン エンジン
Robin Engine

PARTS CATALOG

Model EY14D,B

No.1

 **富士重工業株式会社**

1. クラシケーター……CRANKCASE

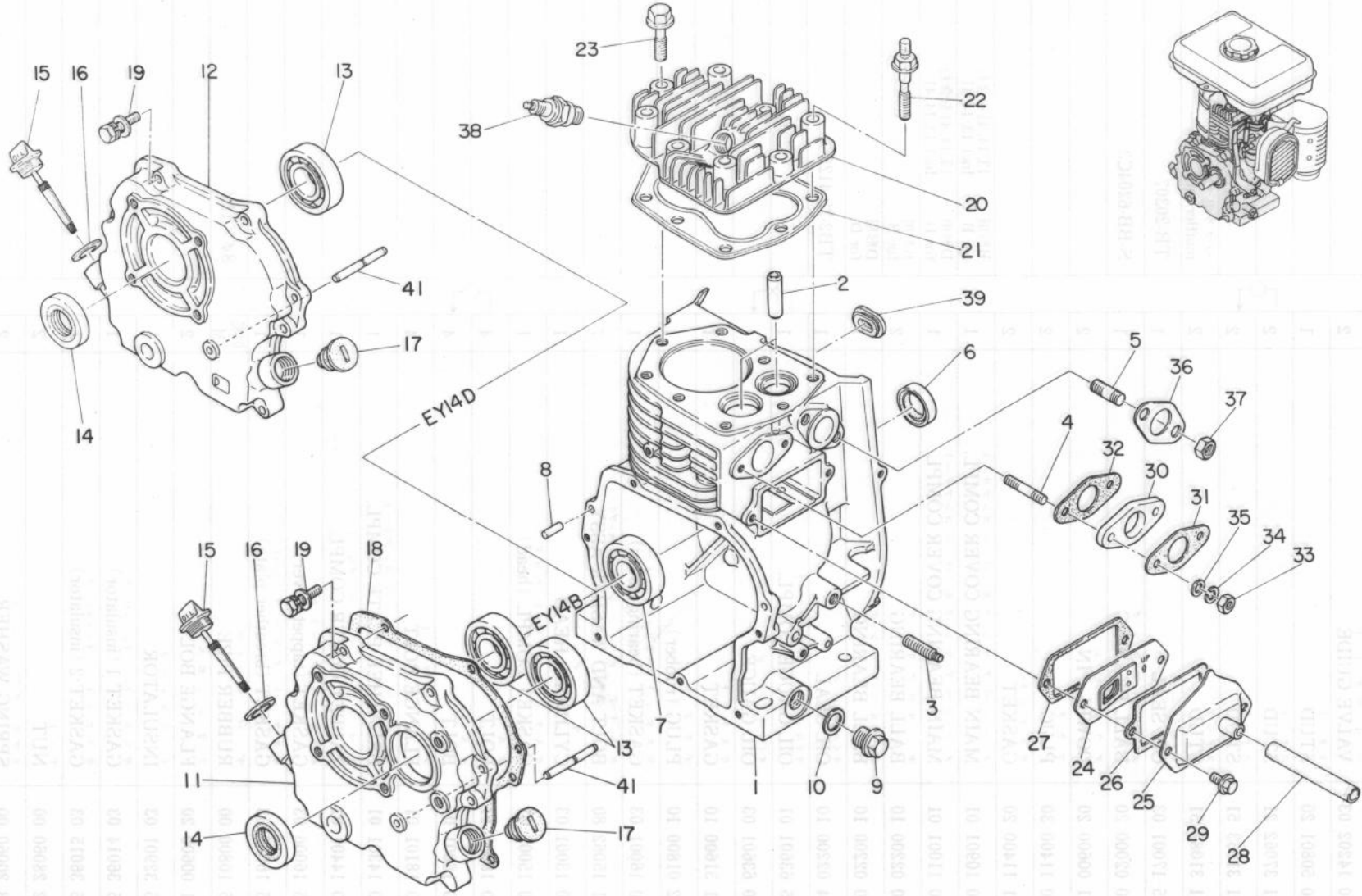

36	330 3000 03	CV2KEE1 (under)
37	003 10060 00	MY2HEK
38	003 30080 00	2L611AC MY2HEK
39	003 32050 00	W.L.L
40	312 36012 03	CV2KEE1.3 (under)
41	312 36013 03	CV2KEE1.1 (under)
42	312 35001 03	1Z611TAK
43	011 0006 30	1Z611ACE 10
44	092 10060 00	KT6BEK
45	302 11000 00	CV2KEE1
46	312 14000 00	CV2KEE1.3 (under)
47	330 14000 00	CV2KEE1.1 (under)
48	330 8100 01	CV2KEE1
49	330 17000 00	CV2KEE1
50	330 19001 04	CV2KEE1
51	001 12005 30	CV2KEE1
52	330 19000 03	CV2KEE1
53	043 01800 10	CV2KEE1
54	081 21000 10	CV2KEE1
55	330 03001 02	CV2KEE1
56	312 03001 01	CV2KEE1
57	044 03300 10	CV2KEE1
58	060 03300 10	CV2KEE1
59	060 03300 10	CV2KEE1
60	330 11001 01	CV2KEE1
61	330 10801 01	CV2KEE1
62	031 11400 50	CV2KEE1
63	040 11400 30	CV2KEE1
64	031 00900 50	CV2KEE1
65	060 03000 10	CV2KEE1
66	312 13001 01	CV2KEE1
67	001 21000 01	CV2KEE1
68	001 21000 01	CV2KEE1
69	001 31003 01	CV2KEE1
70	010 30801 50	CV2KEE1
71	330 14305 02	CV2KEE1
72	330 10101 01	CV2KEE1

2. クランクシャフト, カムシャフト, ピストン.....CRANKSHAFT, CAMSHAFT and PISTON

